

CHARACTERISTICS

- IN COMPLIANCE WITH 94/9/CE 'ATEX STANDARDS'

II 2GD ck IIC+H2
T100 °C IP65

- ONE OR TWO PUMP MODULES

- 3 LEVELS AVAILABLE:

- MINIMUM AND MAXIMUM FLOATING LEVEL

- MINIMUM AND MAXIMUM LASER LEVEL

- MINIMUM LEVEL CAPACITANCE

- "QUICK SWAP" PUMP MODULE: EASY OUTPUTS SUBSTITUTION WITHOUT DISRUPTION TO PIPE-WORK DURING PUMP MAINTENANCE

- RESERVOIR CAPACITY: 10 KG, 30 KG

- FLOW: 25CC/MIN

A COMPACT GREASE PUMP PACKAGE SUITABLE FOR POTENTIALLY HAZARDOUS AREAS

Mini-SUMO Atex is a MiniSumo variant in compliance with 94/9/CE 'ATEX standards', engineered for potentially hazardous areas.

The electric **mini-SUMO Atex** pump is fully protected against the external environment and can run without problems in the most severe ambient conditions.

The **mini-SUMO Atex** Pump is ideal for those applications that use Series 26 - progressive system and O2 Dual Line System. It is designed to feed oil and grease lubrication systems and is compatible with greases up to grade NLGI-2.

ZERO DOWNTIME DURING PUMP MAINTENANCE

The QUICKSWAP SYSTEM allows to quickly replacement of the PUMP MODULES simply by removing and replacing with new ones. No pipe work needs to be disrupted and this means lower possibility of contamination.



ENGINEERED FOR POTENTIALLY HAZARDOUS AREAS
II 2GD ck IIC+H2 T100 °C IP65

APPLICATION

- HAZARDOUS AREAS
- STEEL INDUSTRY
- OIL&GAS INDUSTRY

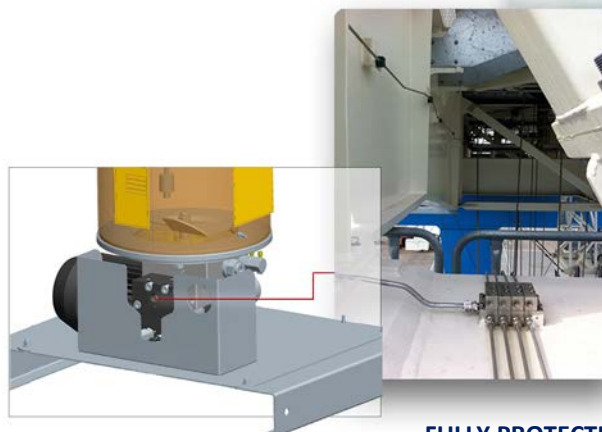

**FULLY PROTECTED AGAINST THE EXTERNAL ENVIRONMENT
CAN RUN WITHOUT PROBLEMS
IN THE MOST SEVERE AMBIENT CONDITIONS**

LUBRICATION SYSTEM EXAMPLES

HYDRAULIC DIAGRAM FOR GREASE PUMP WITH ELECTROPNEUMATIC SWITCH – DUAL LINE SYSTEM

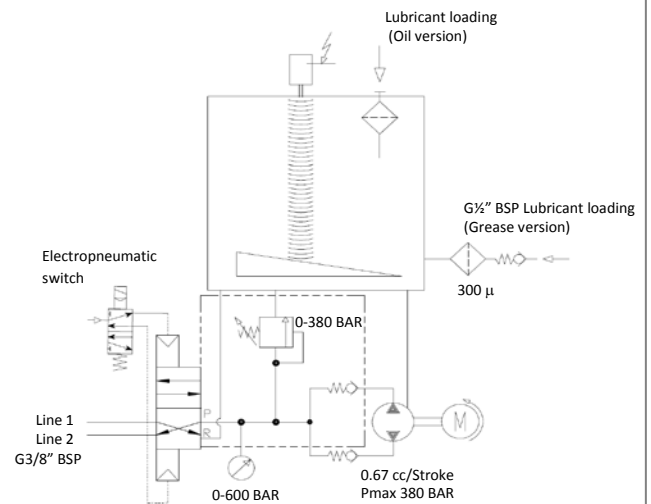
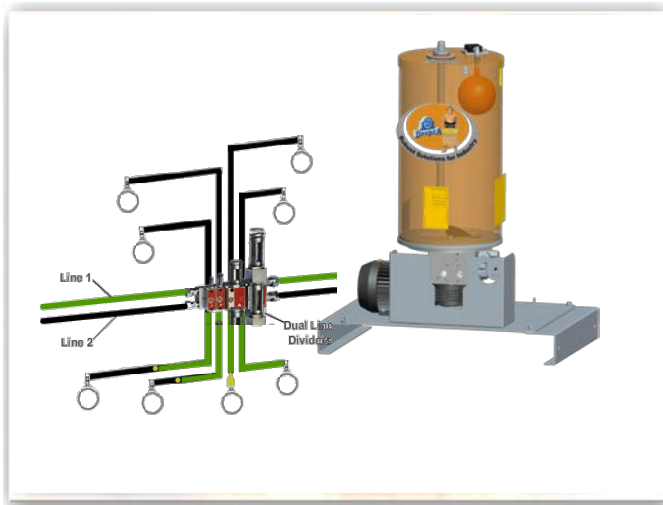

HYDRAULIC DIAGRAM FOR STANDARD PUMP WITH SINGLE GREASE OUTLET – PROGRESSIVE SYSTEM

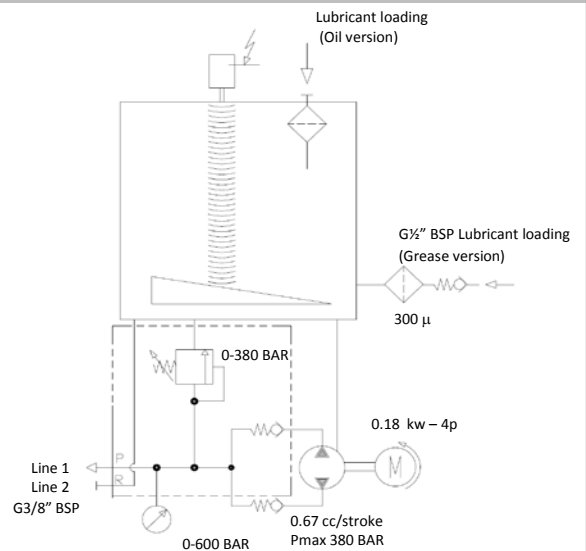
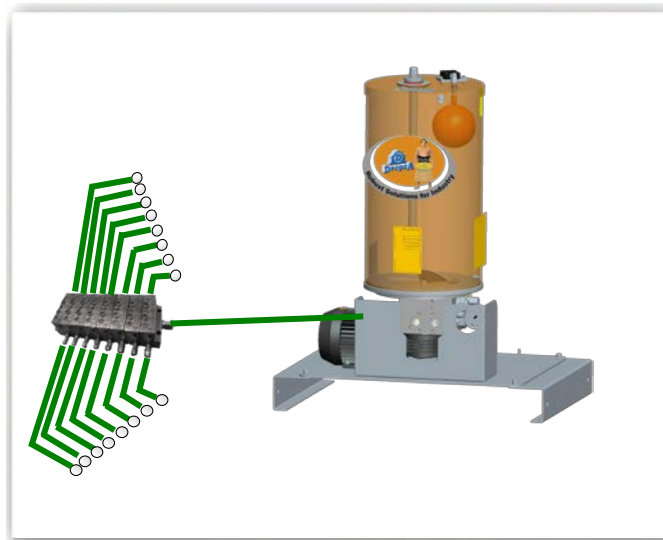

TECHNICAL INFORMATION

GENERAL CHARACTERISTICS	
Empty weight (10 Kg reservoir)	62 Kg
Empty weight (30 Kg reservoir)	65 Kg
Empty weight pump without reservoir	42 Kg
ELECTRICAL CHARACTERISTICS	
Motor power supply	3 Ph - 0,25 Kw - 230Δ/400Y 50/60 Hz – Maximum working voltage 690V.
Motor degree of protection	IP 65
Minimum and maximum level	Capacitive-laser-ultrasounds
HYDRAULIC CHARACTERISTICS	
Pumping system	Piston
Flow rate (per pumping element)	25 cc/min
Maximum operating pressures	380 bar
Outlet connection	G3/8" BSP
Loading filter	Degree of filtering 300 μ
By-pass	Adjustable 0÷380 bar – precalibrated 300 bar
Temperature of use	- 5 ÷ + 50 °C
Operating humidity	90 % rel. humidity
Permitted lubricants	Mineral lubricating oil min 32 cSt; grease max NLGI2

OVERALL DIMENSIONS (NOT TO SCALE)

VERSION WITH RESERVOIR

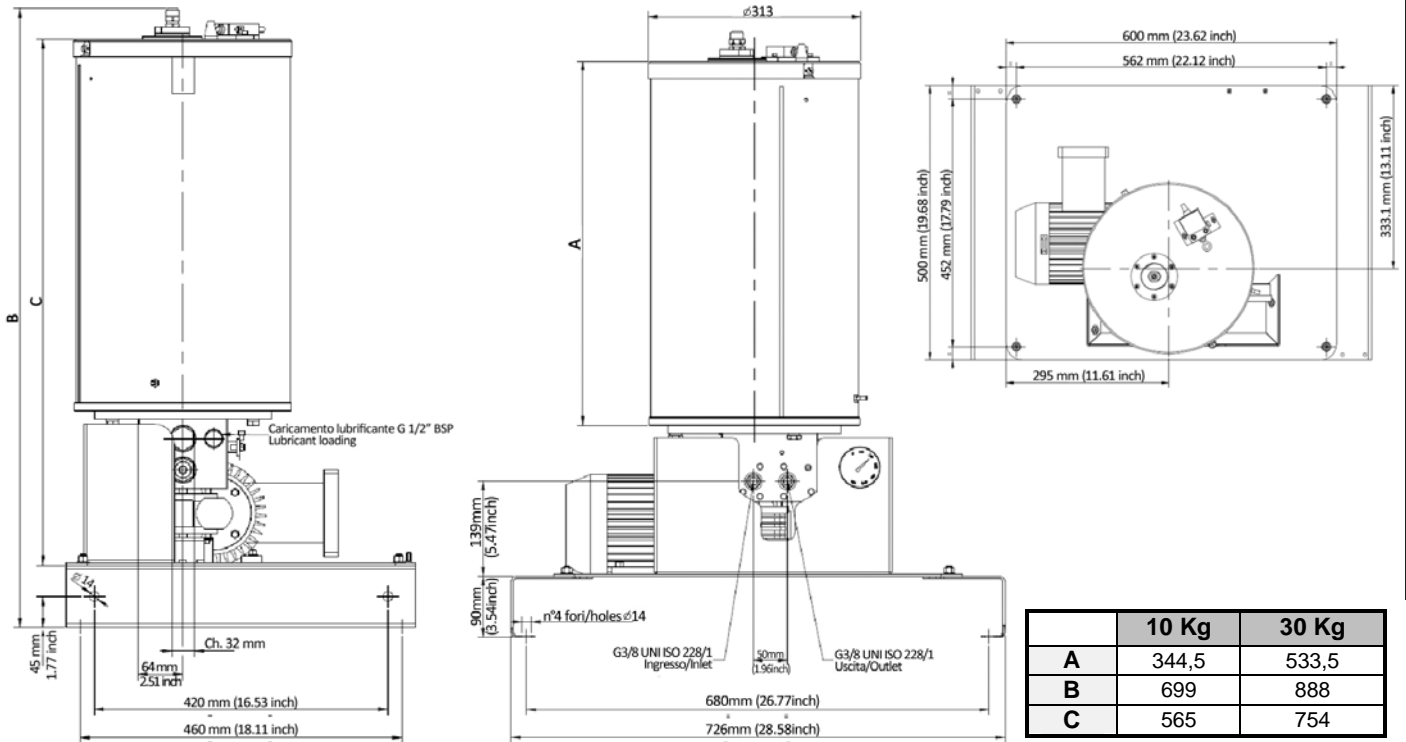

VERSION WITHOUT RESERVOIR

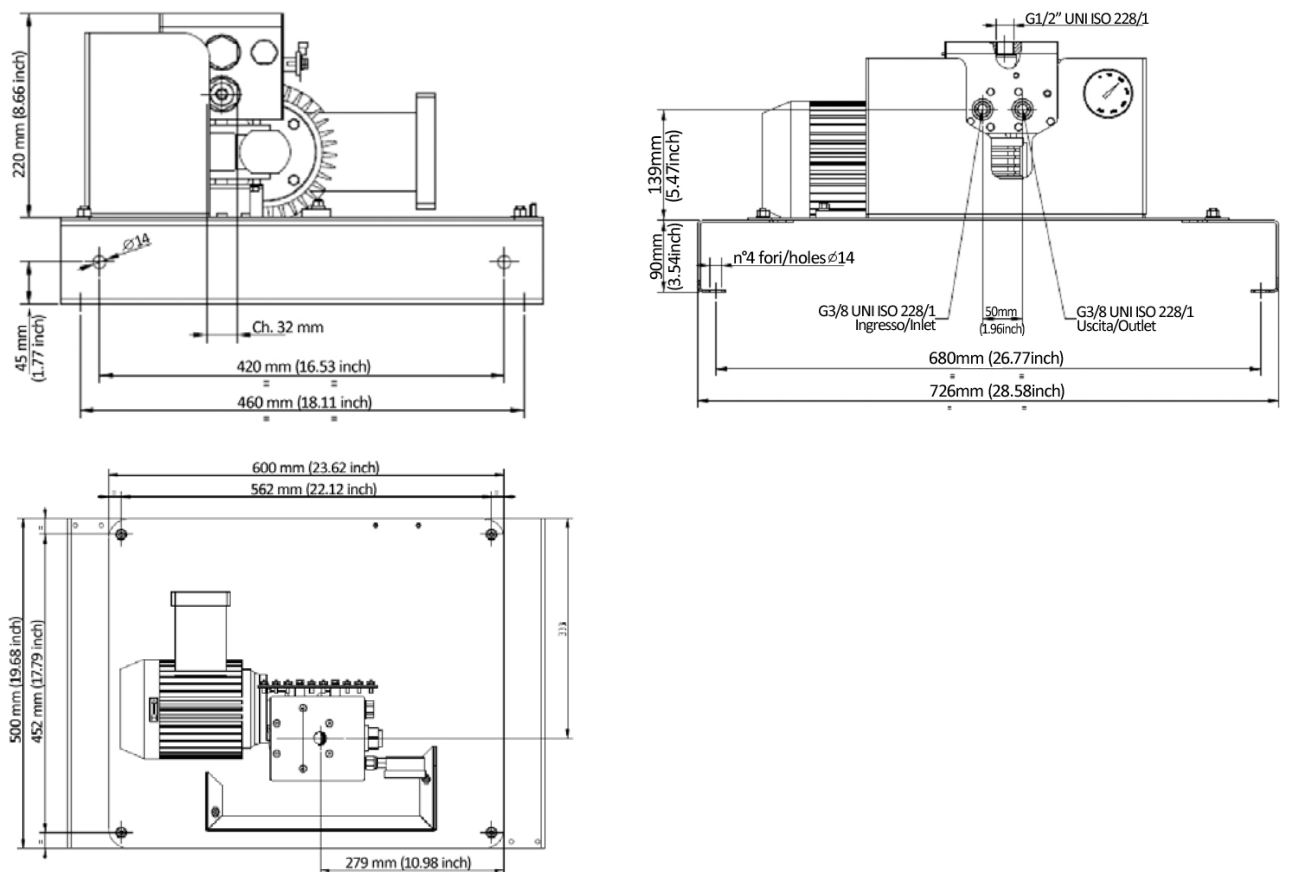

ORDERING INFORMATION

AVAILABLE VERSION			
PUMP	RESERVOIR	DESCRIPTION	PART NUMBER
Mini-SUMO GRASSO	10 kg	Grease standard version - Capacitive Exi (minimum)+Micro switch Exd (Max)	2487200
	30 Kg	Grease standard version - Capacitive Exi (minimum)+Micro switch Exd (Max)	2487201
Mini-SUMO OLIO	10 kg	Oil standard version - Exd floating level	2487250
	30 Kg	Oil standard version - Exd floating level	2487251
	-	Minisumo ATEX OIL pump without reservoir - 3ph-0.25kW	2487220

ACCESSORIES		
PRODUCT	DESCRIPTION	PART NUMBER
Maximum and Minimum level	30 kg Pump laser level kit - Exd case	0295145
Electro pneumatic Change-over Kit	24 V DC	0083470+0295047
	24 V AC	0083471+0295047
	110 V AC	0083472+0295047
	230 V AC	0083473+0295047
Hydraulic Change-over		0086450
Terminal board	Terminal board with wiring	1525722

SPARE PARTS	
DESCRIPTION	PART NUMBER
Motor - 3 Ph - 0,25 Kw - 230Δ/400Y 50Hz - 1350 rpm	0297040
Capacitive Exi level kit (minimum)+Microswitch Exd (Max) 10 Kg	0297075
Capacitive Exi level kit (minimum)+Microswitch Exd (Max) 30 Kg	0297061
Laser pump kit level 30 kg cover Exd	0295145
Kit floating level 10 Kg Exd	0295152
Kit floating level 30 Kg Exd	0295153
Flow rate pumping 0.67cc/turn	0297010C
Electric pneumatic change-over 24V DC	0083470
Electric pneumatic change-over 24V AC	0083471
Electric pneumatic change-over 110V AC	0083472
Electric pneumatic change-over 230V AC	0083473
ATEX EExm 24 V DC Coil	3150108
ATEX EExm 24 V AC Coil	3150109
ATEX EExm 110 V AC Coil	3150110
ATEX EExm 230 V AC Coil	3150111
5/2-1/8" NC solenoid valve	3155222
Cycle sensor	1655332
Grease loading filter	0297007
Hydraulic change-over	0086450
by-pass	0234496
Tank - pump casing gasket	3190485
Pressure gouge 0 - 600 Bar	3292154
Gland Exd	0075052

Distributor Info: