

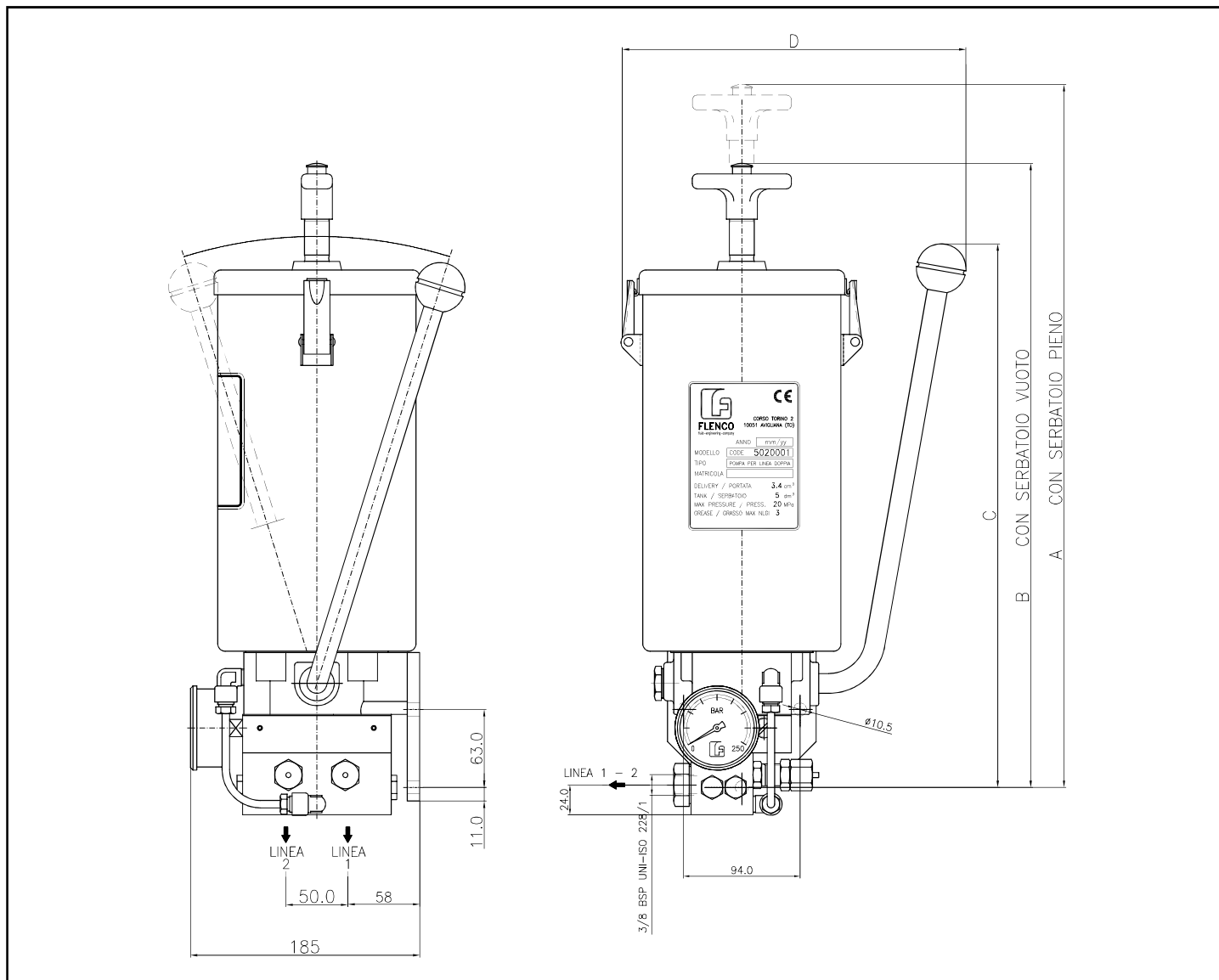

**POMPE MANUALI PER GRASSO  
PER IMPIANTI A DOPPIA LINEA**
**MANUAL PUMPS FOR GREASE  
FOR DUAL LINE SYSTEMS**

**CARATTERISTICHE TECNICHE:**

Portata azionamento: 3,4 cm<sup>3</sup>  
 Capacità serbatoio: 5 kg - 2 kg - 1 kg  
 Pressione di inversione: 3-30 MPa  
 Pressione utilizzo max: 20 MPa

**TECHNICAL CHARACTERISTICS:**

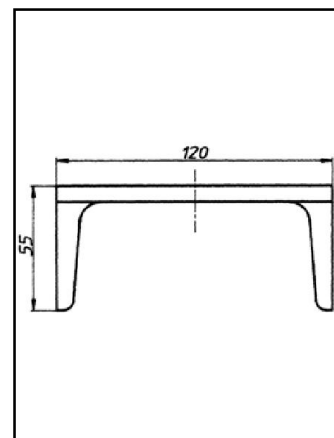
Start up output: 3,4 cm<sup>3</sup>  
 Tank capacity: 5 kg.- 2 kg.- 1 kg.  
 Reversing pressure: 3-30 MPa (435-4350 PSI)  
 Max working pressure: 20 MPa (2900 PSI)

Codice Code	Capacità serbatoio / Tank capacity Kg.	Dimensioni / Dimensions			
		A	B	C	D
5020001	5	745	504	440	278
5020002	2 con molla / with spring	866	577	439	272
5020005	1 con molla / with spring	462	355	439	272



Per il fissaggio delle pompe serie 5020...  
 Peso kg 3,70  
 Vite **Code 9241934**  
 Dado **Code 9169032**  
 Rosetta **Code 9264066**  
 Piastre a saldare a U **Code 8278003**

For 5020 series pumps fixing 5020...  
 Weight kg.3,70  
 Screw **Code 9241934**  
 Nut **Code 9169032**  
 Ring **Code 9264066**  
 Plates to be U welded **Code 8278003**

