

Product description
Pump BM-B

APPLICATION

The BM-B pump, because of its constructional characteristics, may be used in single line-, dual line-, progressive- and spray lubricating systems.

Regardless of the number of lubrication points, the pump can be effectively adapted to meet any requirements. It can also be used for refilling and mobile greasing systems.

PRODUCT CHARACTERISTICS

- Discharge pressure adjustable up to max. 400 bar
- High reliability due to forced control
- Discharge: 2 and 4 liters/h, depends on driving speed
- Geared motors
- Long service life thanks to the use of wear-resistant high-grade steel
- Compact and rugged design
- Lubricant: oil, grease, liquid grease
- Surface signal grey RAL 7004



FUNCTION

The pump can be supplied complete with a geared motor. It consists essentially of a housing with pump unit and an integral lubricant reservoir.

The delivery and control plungers of the pump element are driven by eccentric cams to which they are rigidly connected. As a result there of, they are positively controlled.

A blockage (as may happen with spring-controlled plungers or a hydraulic pressure transfer) is not possible. The required delivery pressure can be adjusted by means of an integrated pressure relief valve. It prevents damages to the pump in the event of an inadmissibly high counter-pressure situations. The pump need not be vented.



A. PUMP TYPE	Code
	BMB
B. NUMBER OF OUTLETS	Code
1 outlet	01
C. REVISION	Code
Status A	A
D. KINDS OF DRIVE	Code
Flange-mounted geared motor 220 - 240 / 380 - 415 / 50 Hz, 0.18 kW, 63 min ⁻¹	01
Flange-mounted geared motor 220 - 240 / 380 - 415 / 50 Hz, 0.37 kW, 63 min ⁻¹	02
Flange-mounted geared motor 220 - 240 / 380 - 415 / 50 Hz, 0.37 kW, 125 min ⁻¹	03
Flange-mounted geared motor 500 - 525 / 50 Hz, 0.37 kW, 63 min ⁻¹	04
Flange-mounted geared motor 500 - 525 / 50 Hz, 0.37 kW, 125 min ⁻¹	05
Flange-mounted geared motor UL / 3 / PE 115 V / 60 Hz, 0.21 kW, 63 min ⁻¹	21
Flange-mounted geared motor UL / 3 / PE 115 V / 60 Hz, 0.37 kW, 63 min ⁻¹	22
Flange-mounted geared motor UL / 3 / PE 115 V / 60 Hz, 0.37 kW, 125 min ⁻¹	23

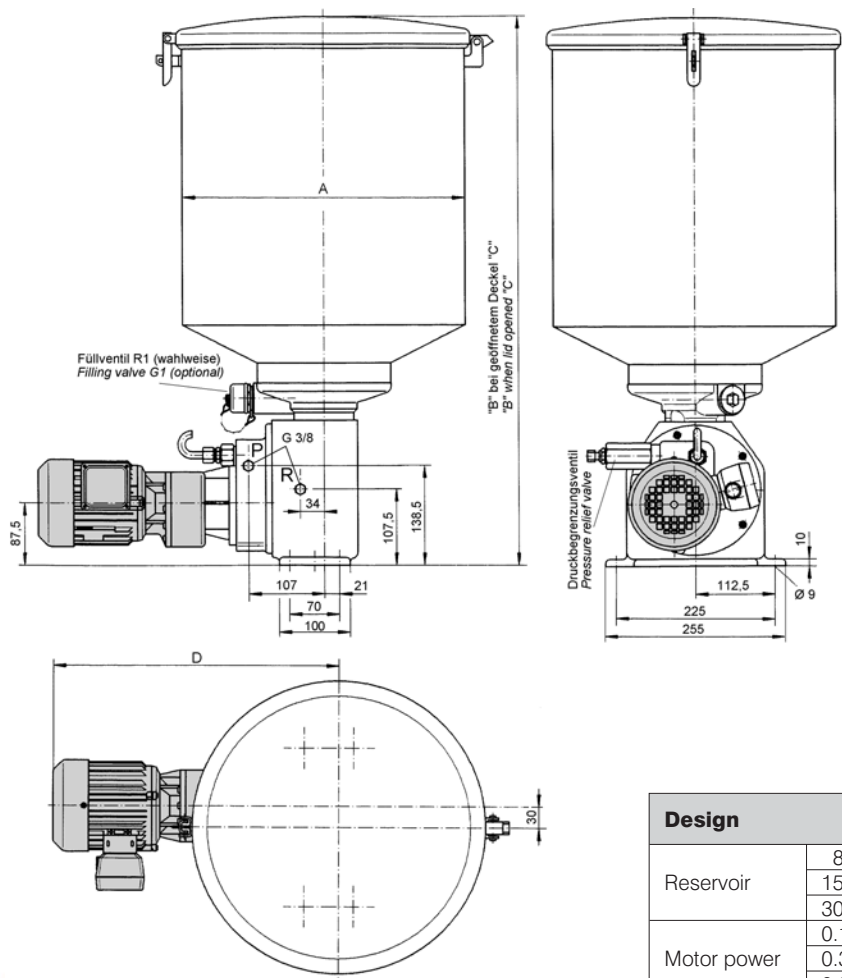

Design		Dimensions (mm)			
		A	B	C	D
Reservoir	8 l	Ø 190	595	785	
	15 l	Ø 240	630	870	
	30 l	Ø 310	700	1010	
Motor power	0.18 kW for 63 min ⁻¹				406
	0.37 kW for 63 min ⁻¹				432
	0.37 kW for 125 min ⁻¹				424



E. POSITION OF DRIVE	Code
-----------------------------	-------------

without	0
---------	---

F. RESERVOIR	Code
---------------------	-------------

8 liters	A
15 liters	B
30 liters	C

G. ACCESSORIES	Code
-----------------------	-------------

without	00
Level switch	01

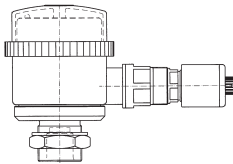

A level switch is available for the indication of the filling level in the reservoir. As sensor serves an ultrasonic sensor. As soon as the min. or max. level allowed has been obtained, a signal is released. With the help of a signal lamp at the reservoir, this signal can be used for the visual warning or for the control of an automatic filling facility.

In case of receiving the order, we will attach particular operating instructions to the level switch with the following code: BA_2005_1_GB_76951_6011.

Pressure gauge	02
Level switch and pressure gauge	03

EXAMPLE OF ORDER

Code											
B	M	B	0	1	A	0	1	O	A	0	1

Pump type BM-B	Code: BMB	
Number of outlet 1 outlet	Code: 01	
Revision Status A	Code: A	
Kinds of drive Flange-mounted geared motor 220-240/380-415/50Hz 0.18kW, 63 min ⁻¹	Code: 01	
Position of drive without	Code: O	
Reservoir capacity 8 liters	Code: A	
Accessories Level switch for reservoir 8 liter	Code: 01	



SPECIFICATION

Discharge pressure adjustable up to max. : _____ 400 bar
Discharge volume at : 63 min⁻¹ : _____ 34 cm³/min (2.0 l/h)
125 min⁻¹ : _____ 67 cm³/min (4.0 l/h)
Max. rpm geared motor version : _____ 125 min⁻¹
Direction of rotation of the pump : _____ anticlockwise
Reservoir capacity : _____ 8, 15 or 30 l
Operating temperature according to type : _____ - 20° C up to + 80° C
Compatible lubricants : _____ up to NLGI-class 3 DIN 51818
Mineral oils _____ ISO VG 68 to 1500 (DIN 51519)
Built-in grease filter _____ wire cloth 0,4 x 0,18 DIN 4189
Built-in pressure relief valve : _____ can be adjustable from 0 to 450 bar, set to 400 bar
When using the hydraulic 4/2-way valve SA-K, the set pressure may not exceed 350 bar.

DELIMON

Zentrale

Arminstraße 15
D-40227 Düsseldorf
Postfach 10 20 52
D-40011 Düsseldorf
Telefon: +49 211 7774 0
Telefax: +49 211 7774 210
kontakt@bijurdelimon.com
www.bijurdelimon.com

DELIMON

Niederlassung

Am Bockwald 4
D-08344 Grünhain-Beierfeld

DELIMON

Österreich

Am Spitz 2-3 / Schloßhofer Str. 4-6
Stiege 4, Top 20
A-1210 Wien
Telefon: +43 1 585 66 17
Telefax: +43 1 585 66 17 50
kontakt@bijurdelimon.com
www.bijurdelimon.com

LUBRIMONSA

Spain

Avda. Txori-Erri 38
48150 Sondica - (Vizcaya)
Teléfono: +34 94 453 20 00
Fax: +34 94 453 25 00
spain@bijurdelimon.com
www.bijurdelimon.com

DELIMON-Denco Lubrication

DELIMON-Cooling

United Kingdom

Ramsden Court, Ramsden Road
Rotherwas Industrial Estate
Hereford, HR2 6LR
Phone: +44 (0) 1432 365 000
Fax: +44 (0) 1432 365 001
info@delimon.co.uk
www.bijurdelimon.com

BIJUR Products, Inc.

France

BP 50
ZI de Courtabœuf
5, Avenue de l'Atlantique
91942 Les Ulis Cedex
Tél.: +33 1 692 985 85
Fax: +33 1 690 776 27
contact@bijurdelimon.com
www.bijurdelimon.com

*Für reibungslose Bewegung
For smooth motion*

